

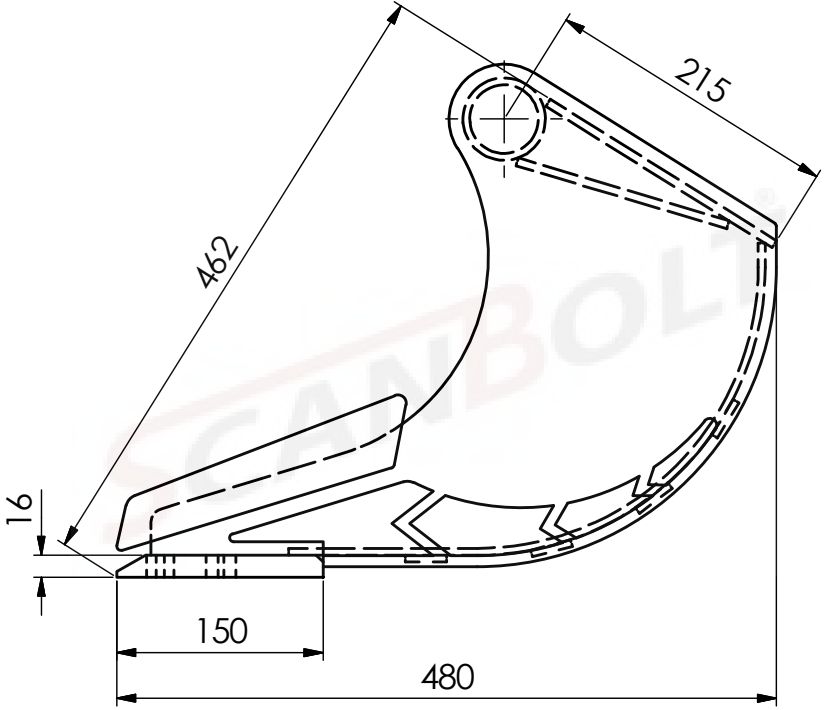

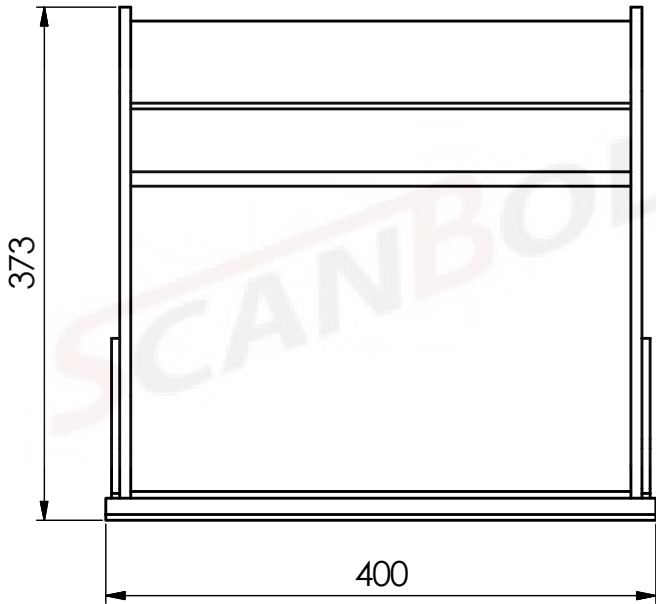

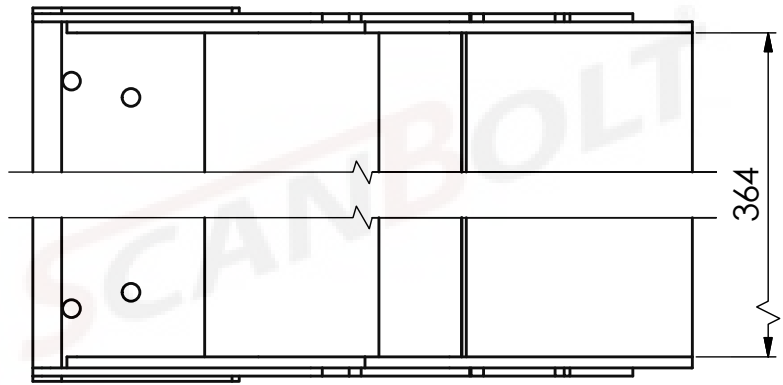

8 7 6 5 4 3 2 1

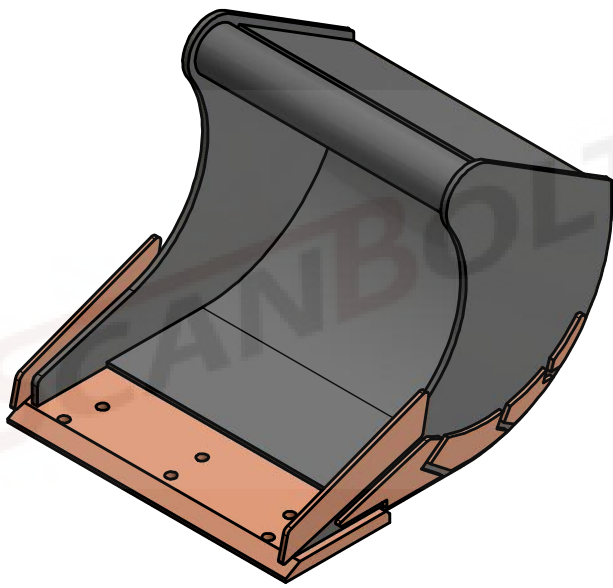

D  
C  
B  
A

D  
C  
B  
A

| MATERIAL SPECIFICATION   |                 |
|--|-----------------|
|  | ST52.3          |
|  | EN8D            |
|  | HB 400          |
|  | HB 450          |
|  | CASTALLOY STEEL |

| <b>SCANBOLT®</b> |                     |
|------------------|---------------------|
| DESCRIPTION      | 40CM DIGGING BUCKET |
| MACHINE CLASS    | 1.3-2.4 TON         |
| WEIGHT           | 37 Kg               |
| HEAPED CAPACITY  | 40.5 LITERS         |

8 7 6 5 4 3 2 1